

# PRIMO

Food & Beverage  
Solutions Provider



# HEAVY DUTY COMMERCIAL BLENDER

## FEATURE:

- Heavy Duty Motor
- Unique Blade Design
- Effective Sound Proof Cover
- 2L Food Grade PC Jar
- Removable Sound Enclosure for Easy Cleaning
- Programmable cycles (8 Pre-set programs)
- Touch Pad Control
- Aluminum Base for Stable Performance
- Magnetic Control Start System
- Current Overload Protection



RoHS CE



**Efficient  
Sound  
Proof Cover**



**Unique  
Blade Design**



**Magnetic  
Control  
Start System**

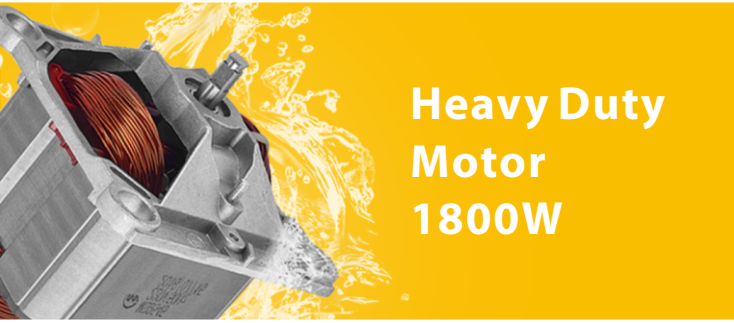

**Heavy Duty  
Motor  
1800W**



**Heat Exhaust  
System**



**Aluminum  
Base  
for Stable  
Performance**

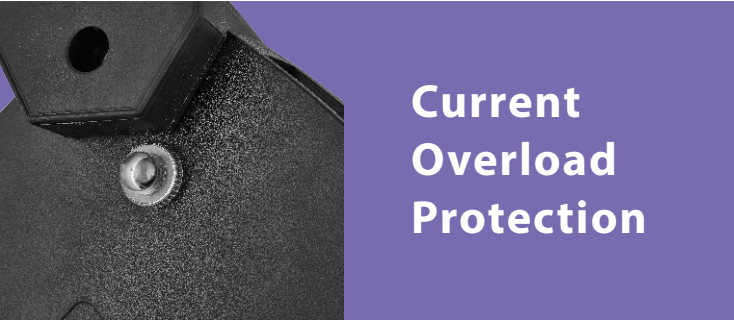

**Current  
Overload  
Protection**

## TECHNICAL SPECIFICATIONS

CODE:	0100100270
SIZE:	230x230x510mm
ROTATE SPEED:	2800RPM
CAPACITY:	2L PC Jar
VOLTAGE:	220V/50Hz
POWER:	1800W

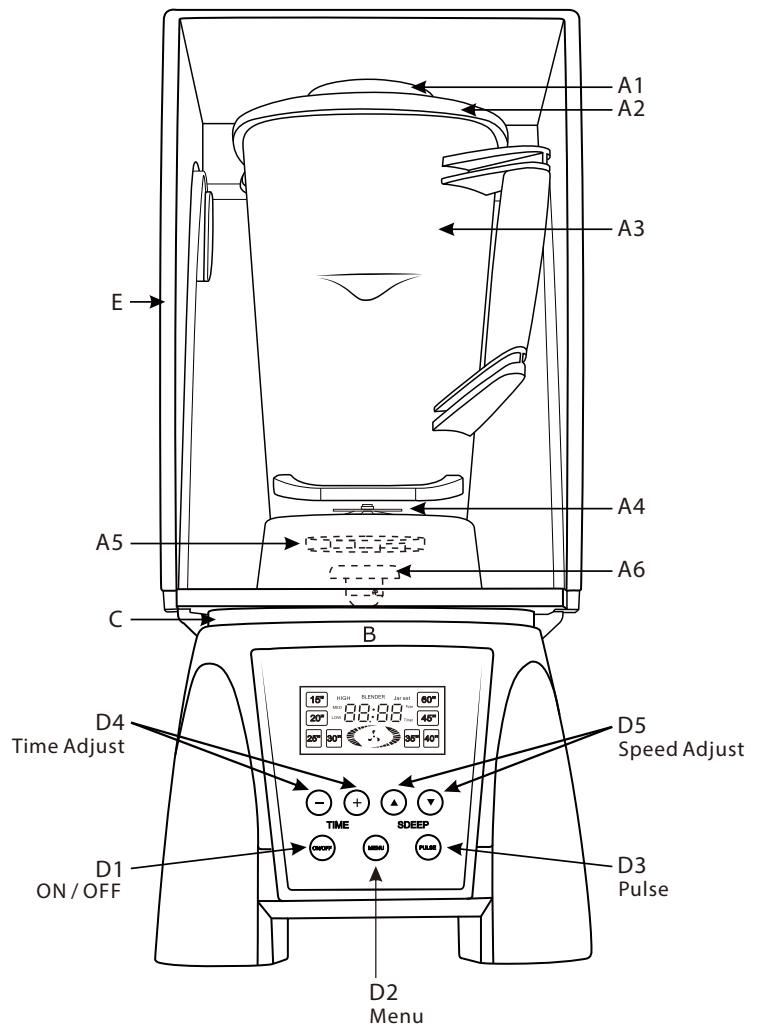

## PRODUCT DESCRIPTION

A1	Filler Cap
A2	Cap Lid
A3	Blender Jug
A4	Cutting Blade
A5	Retainer Nut
A6	Drive Socket
B	Overload Reset
C	Centering Pad
E	Soundproof Cover